

BP Solar's Millennia™ modules are the most cost-effective photovoltaic option for any application where mounting space is not a constraint. While generating the most power for the lowest cost for large areas such as roofs, they provide superb esthetics to blend with modern architecture. With our patented Integra™ framing system, the BP 850 is particularly well-suited for residential and commercial roofs; its interlocking frames enable fast installation and a seamless array appearance. Heat-strengthened glass provides improved impact resistance.

BP Solar is an established leader in thin film technology. The Millennia process creates solar cells by depositing thin layers of semiconductor alloys on glass, then forming individual cells by a patented laser-scribing process. Millennia modules enhance efficiency by stacking two silicon solar cells vertically, with each cell tuned for optimum conversion of different segments of the spectrum.

The BP 850 is available in three configurations:

- Equipped with the Integra™ framing/ mounting/wiring system for low-cost, fast installation and direct roof-mounting;
- Framed with clear anodized Universal extruded aluminum framing and a high-volume junction box, with or without 600mm leads equipped with DC connectors;
- As a frameless laminate with a high-volume junction box, with or without 600mm leads with DC connectors.

In Universal-framed and laminate versions, the BP 850 is well-suited to direct-coupled (batteryless) pumping systems and to large utility-interactive power systems.



Integra Frame

Integra-Framed Modules

The BP 850 is available with BP Solar's patented Integra™ framing/ mounting/ wiring system, which facilitates quick, low-cost installation on most support structures and on sloped surfaces such as roofs. These modules include integral DC plug-together electrical connectors which enable array electrical connection without tools. Once assembled, the connectors are concealed in channels in the bronze-anodized frame, providing smooth,

uncluttered appearance yet easy access for trouble-shooting. For U.S. NEC-compliant installation, additional components are required, and are available in the UL-listed installation kit.

Limited Warranties

Millennia photovoltaics are conservatively rated, taking into account the attenuation which occurs during the first several months of deployment. When first deployed, they generate from 14% to 17% above their rated power. They are covered by limited warranties which warrant:

- Power output for 20 years;
- Freedom from defects in materials and workmanship for 1 year.

See our website or your local representative for full terms of these warranties.

Quality and Safety

The following approvals and certifications have been granted or are pending for the BP 850, with the exceptions noted.

- Recognition (for laminates) or Listing (for modules) by Underwriter's Laboratories for electrical and fire safety (Class B fire rating);
- Certification by TÜV Rheinland as Class II equipment;
- Compliance with Directives 89/336/EEC, 73/23/EEC and 93/68/EEC of the European Community;
- Approval by Factory Mutual Research* for application in NEC Class 1, Division 2, Groups A, B, C & D hazardous locations;
- Compliance with the requirements of IEC 61646.

*Except for Integra-framed products and products with output cables



BP 850



Proven Materials and Products

These products reflect BP Solar's three decades of PV system experience and hundreds of thousands of deployed Millennia products. Their impact resistance is now enhanced by the use of heat-strengthened glass. The module's active area is enclosed by two 3mm sheets of this tough glass, with EVA (ethylene vinyl acetate) providing a weatherproof seal.

New Nomenclature

Old Name	New Name
MST-50	BP 850

The product names in this publication reflect our ongoing conversion to a new naming system. The qualifications and certifications of some products are registered under the prior name.

Electrical Characteristics¹

	BP 850	BP 845 ²
Maximum power ³ (P_{max})	50W	45W
Voltage at P_{max} (V_{mp})	78V	75V
Current at P_{max} (I_{mp})	0.64A	0.6A
Short-circuit current (I_{sc})	0.78A	0.75A
Open-circuit voltage (V_{oc})	101V	100V
Warranted minimum power	45W	40.5W
Design max V_{oc} ⁴	117V	117V
Nominal voltage	48V	48V
Maximum series fuse rating	20A ⁶	
Maximum system voltage ⁵	600V	
Temperature coefficient of power	-(0.22±0.03)%/°C	

Notes

1. These data represent the performance of typical modules as measured at the module output, and do not include the effect of such additional equipment as diodes. The data are based on measurements made in accordance with ASTM E1036 corrected to SRC (Standard Reporting Conditions, also known as STC or Standard Test Conditions), which are:
 - illumination of 1 kW/m² (1 sun) at spectral distribution of AM 1.5 (ASTM E892 global spectral irradiance);
 - cell temperature of 25°C.
2. The power of Millennia modules varies in the normal course of production; the rating of this product reflects that variance.
3. Stabilized value.
4. For maximum system voltage design calculations.
5. U.S. NEC rating.
6. 15A for products with cables and connectors

BP 850 I-V Curves

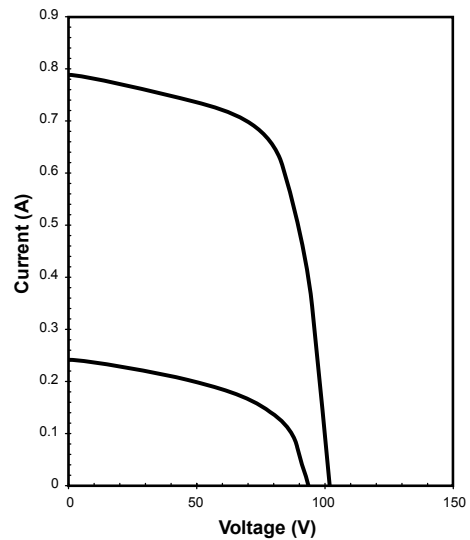

Curve Conditions:

All curves at cell temperature of 25°C and spectral distribution of AM 1.5; upper curve at 1kW/m² illumination; lower curve at 250 W/m² illumination.

Mechanical Characteristics

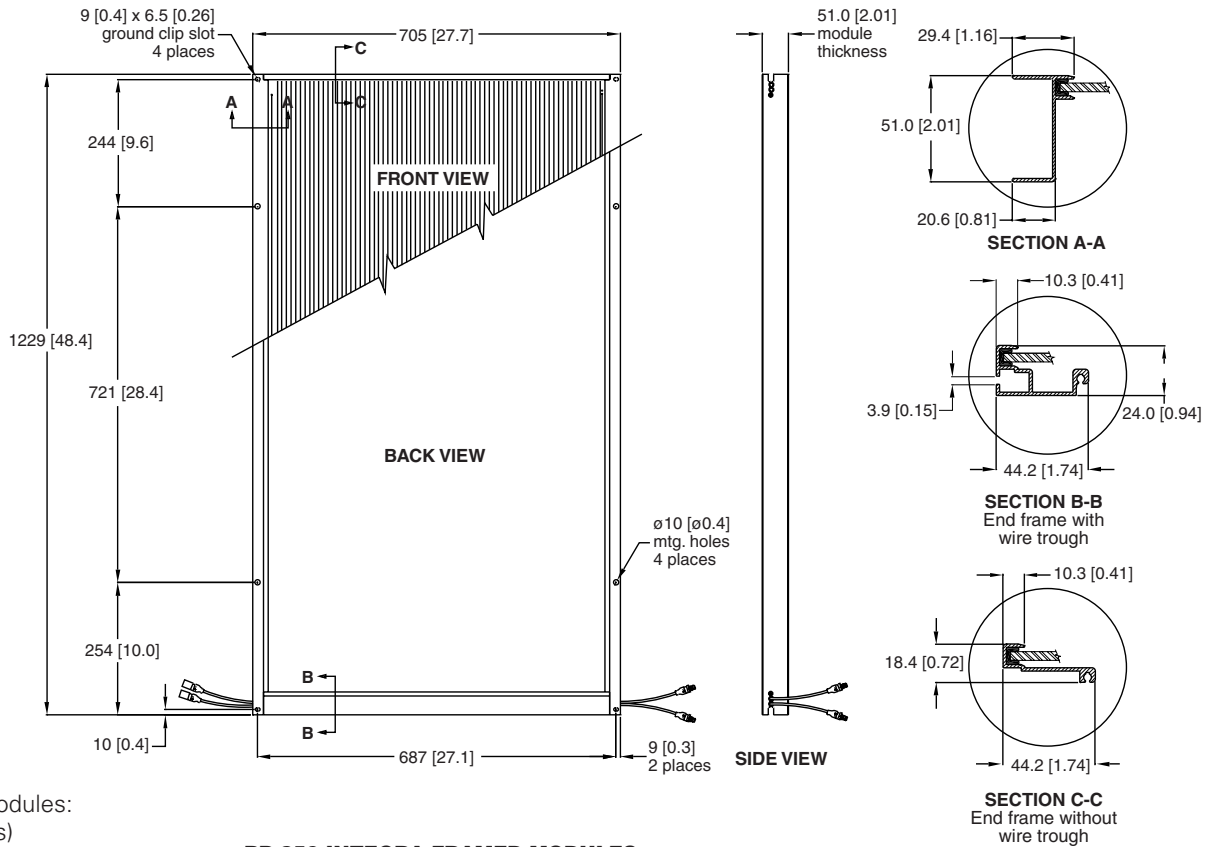

Weight

Universal-framed modules:

15 kg (33.1 pounds)

Integra-framed modules:

14.5 kg (32 pounds)

Laminates:

12.9 kg (28.5 pounds)

Wiring

Laminates and Universal-framed modules where applicable:

600mm long, 1.5mm² (AWG #16)

Integra-framed modules:

1mm² (AWG #17); cable pairs extend approximately 145mm beyond module, enabling side-by-side or end-to-end module placement.

Dimensions

Laminate overall dimensions:

657 [25.9] X 1219 [48] X 6.6 [0.26]

(50 [2.0] depth including junction box)

Dimensions in brackets are in inches

Unbracketed dimensions are in millimeters

Overall tolerances ±3mm (1/8")

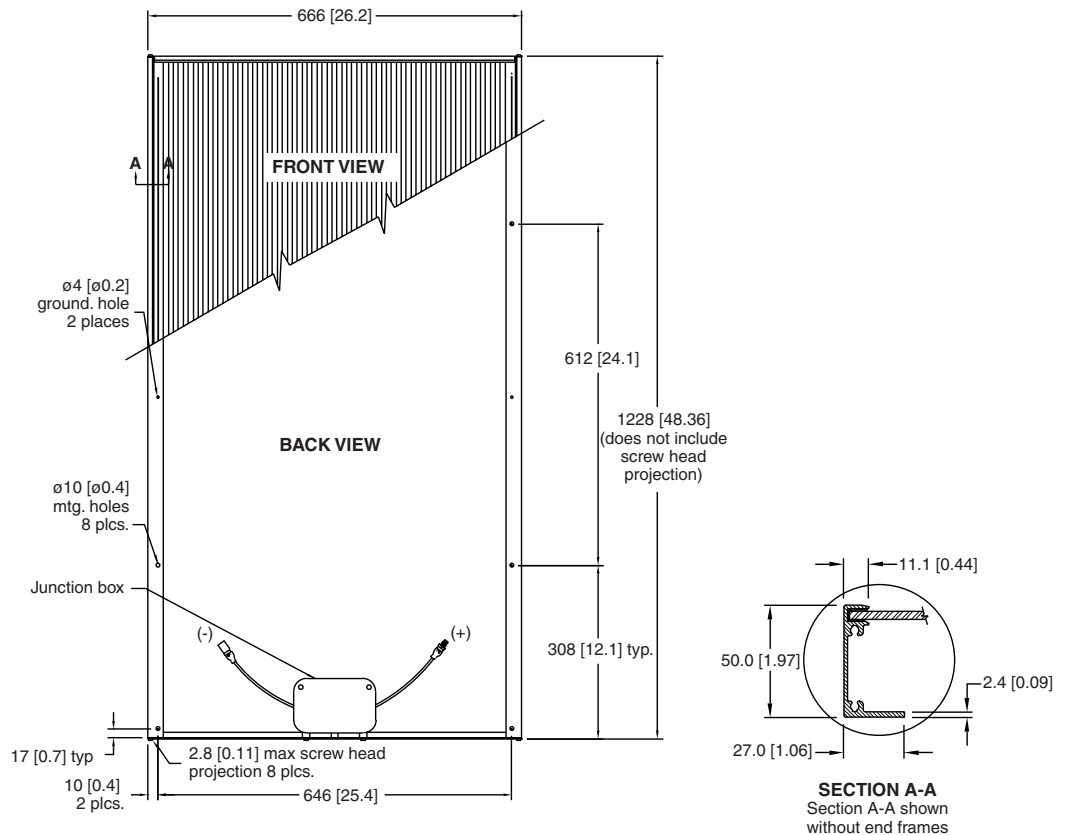



bp solar

This publication summarizes product warranty and specifications, which are subject to change without notice and should not be used as the definitive source of information for final system design. Additional warranty and technical information may be found on our website www.bpsolar.com or may be obtained from your local representative.



Printed on recycled paper with vegetable based inks.